

BD30A SERIES BRUSHLESS SERVO AMPLIFIERS

Models: BD30A8, BD25A20

FEATURES:

- Surface-mount technology
- Small size, low cost, ease of use
- Input signal isolation
- Four quadrant regenerative operation
- Hall sensor commutation
- Agency Approvals:

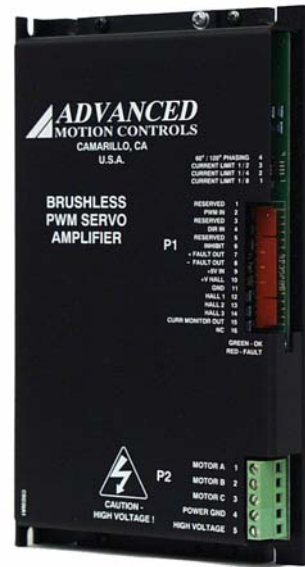

BLOCK DIAGRAM:

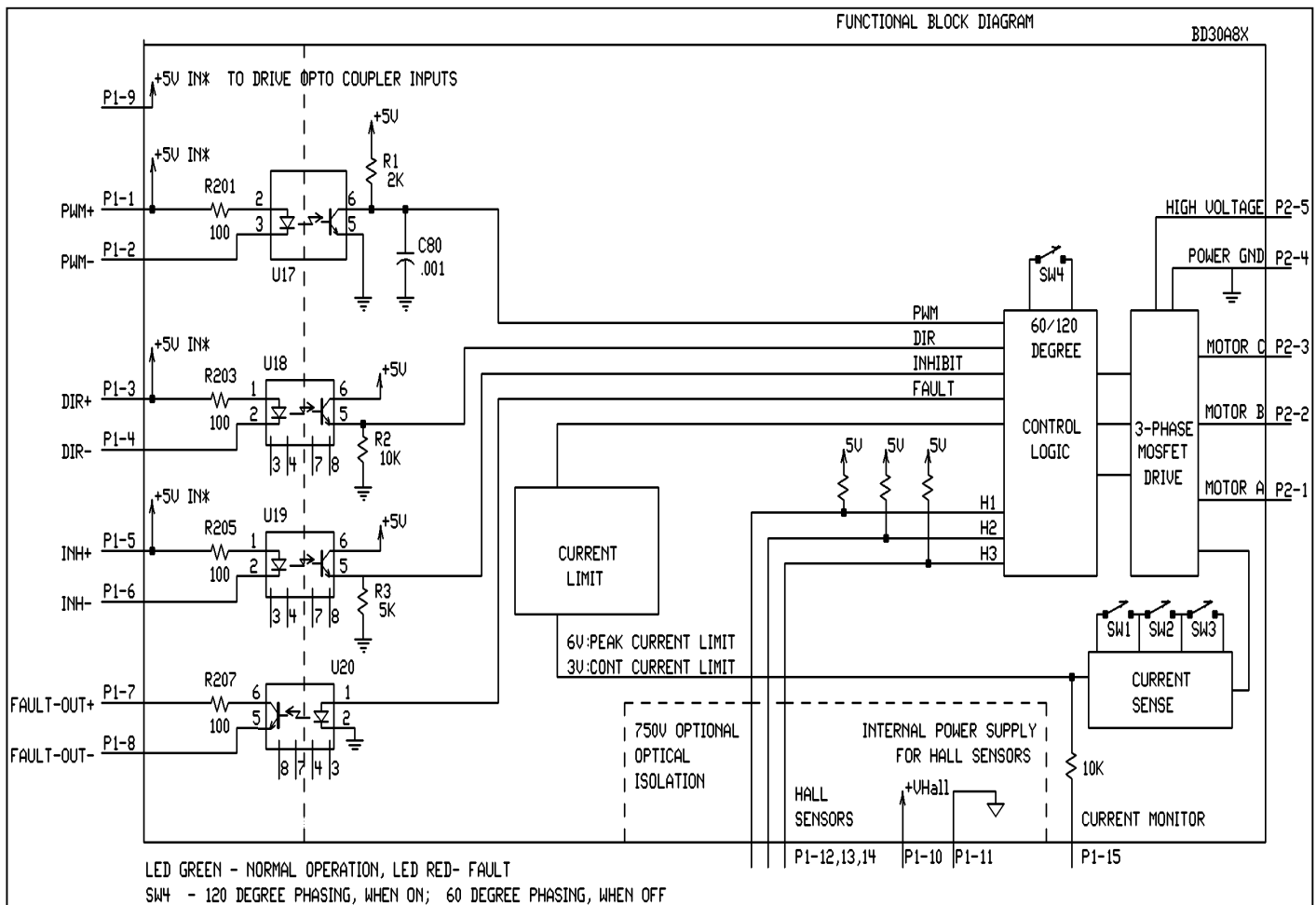

ADVANCED MOTION CONTROLS
 3805 Calle Tecate, Camarillo, CA 93012 Tel: (805) 389-1935, Fax: (805) 389-1165

DESCRIPTION: The BD30A Series PWM servo amplifiers are designed to drive brushless DC motors at a high switching frequency. They are fully protected against over-voltage, over-current, over-heating and short-circuits. All models interface with digital controllers that have a digital PWM output. PWM IN determines the output duty cycle. DIR IN determines the direction of rotation. A single red/green LED indicates operating status. The current limit can be set by DIP switches.

SPECIFICATIONS:

POWER STAGE SPECIFICATIONS	MODELS	
	BD30A8	BD25A20
DC SUPPLY VOLTAGE	30 - 80 V	40 - 190 V
PEAK CURRENT (2 sec. max., internally limited)	± 30 A	± 25 A
MAX. CONTINUOUS CURRENT (internally limited)	± 15 A	± 12.5 A
MINIMUM LOAD INDUCTANCE*	200 µH	250 µH
SWITCHING FREQUENCY	5 - 20 kHz ±15%	
HEATSINK (BASE) TEMPERATURE RANGE	0° to +65° C, disables if > 65° C	
POWER DISSIPATION AT CONT. CURRENT	60 W	125 W
OVER-VOLTAGE SHUT-DOWN (self reset)	86 V	195 V

MECHANICAL SPECIFICATIONS	
POWER CONNECTOR	Screw terminals
SIGNAL CONNECTOR	Molex connector
SIZE	7.35 x 4.40 x 1.00 inches 186.7 x 111.7 x 25.4 mm
WEIGHT	1.5 lb. 0.68 kg

* Low inductance motors require external inductors.

PIN FUNCTIONS:

CONNECTOR	PIN	NAME	DESCRIPTION / NOTES	I/O
P1	1	PWM+	Same as pin 9	I
	2	PWM-	Pulse width modulated digital input	I
	3	DIR+	Same as pin 9	I
	4	DIR-	Direction input	I
	5	INH+	Same as pin 9	I
	6	INH-	Pull low to enable	I
	7	+FAULT	Output transistor turns on and becomes high during output short circuit, over-voltage, over temperature, inhibit, and during power-up reset. Fault condition indicated by red LED.	O
	8	-FAULT		
	9	+5 IN	+5 V @ 150 mA in to drive opto coupler inputs.	I
	10	+V HALL OUT	Power for HALL sensors, Short circuit protected, + 6 V @ 30 mA. See optical signal isolation option below.	O
	11	GND		GND
	12	HALL 1	HALL sensor inputs, logic levels, internal 5 K Ω pull-up. Maximum low level input is 1.5 V, Minimum high level input is 3.5 V. See optical signal isolation option below.	I
	13	HALL 2		
	14	HALL 3		
	15	CURRENT MONITOR OUT	Current monitor. This signal is proportional to the actual current in the motor leads. See current limit adjustments section below for scaling.	O
	16	Reserved		
P2	1	MOTOR A	Motor phase A connection	O
	2	MOTOR B	Motor phase B connection	O
	3	MOTOR C	Motor phase C connection	O
	4	POWER GND	Power ground	GND
	5	HIGH VOLTAGE	DC power input	I

SET-UP: See section "G" for engineering and installation notes.

CURRENT LIMIT ADJUSTMENTS:

These amplifiers feature peak and continuous current limit adjustments. DIP switches reduce both peak and continuous current limit. The ratio of peak/continuous current limit is fixed (50%). The switches also adjust the scaling of CURR-MONITOR output.

SW1	SW2	SW3	Peak current (% of max.)	Continuous current (% of max. cont.)	Current Monitor Scaling
ON	ON	ON	100 %	100 %	4 A/V
ON	ON	OFF	50 %	50 %	2 A/V
ON	OFF	OFF	25 %	25 %	1 A/V
OFF	OFF	OFF	12.5 %	12.5 %	0.5 A/V

The actual current can be monitored at pin P1-15 and is referenced to POWER GND P2-4.

OPTICAL INPUT SIGNAL ISOLATION:

PWM, DIR, INH, FAULT inputs are always isolated from the power section. If the isolation option is selected the Hall sensor inputs (P1-10 through 14) are also isolated. If the isolated version is not ordered, an isolated power supply should be used with this series of amplifiers.

ORDERING INFORMATION:

Models: BD30A8X, BD25A20X

With isolation:

Models: BD30A8IX, BD25A20IX

X indicates the current revision letter.

MOUNTING DIMENSIONS: See page F-9.