

SX30A SERIES THREE PHASE SINUSOIDAL BRUSHLESS SERVO AMPLIFIERS

Model: *SX30A8, *SX25A20

FEATURES:

- Surface-mount technology
- Small size, low cost, ease of use
- Sinusoidal drive and current control
- Optical isolation, see block diagram
- Four quadrant regenerative operation
- Agency approvals:

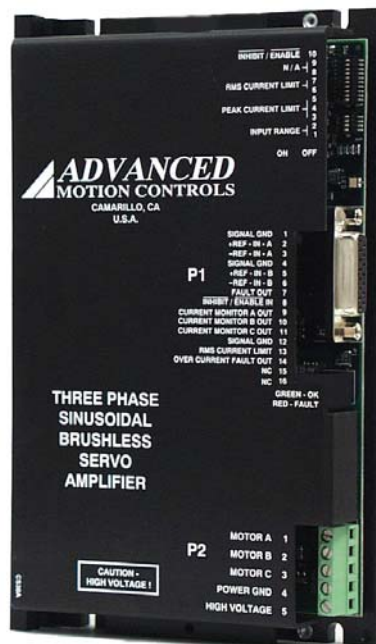

BLOCK DIAGRAM:

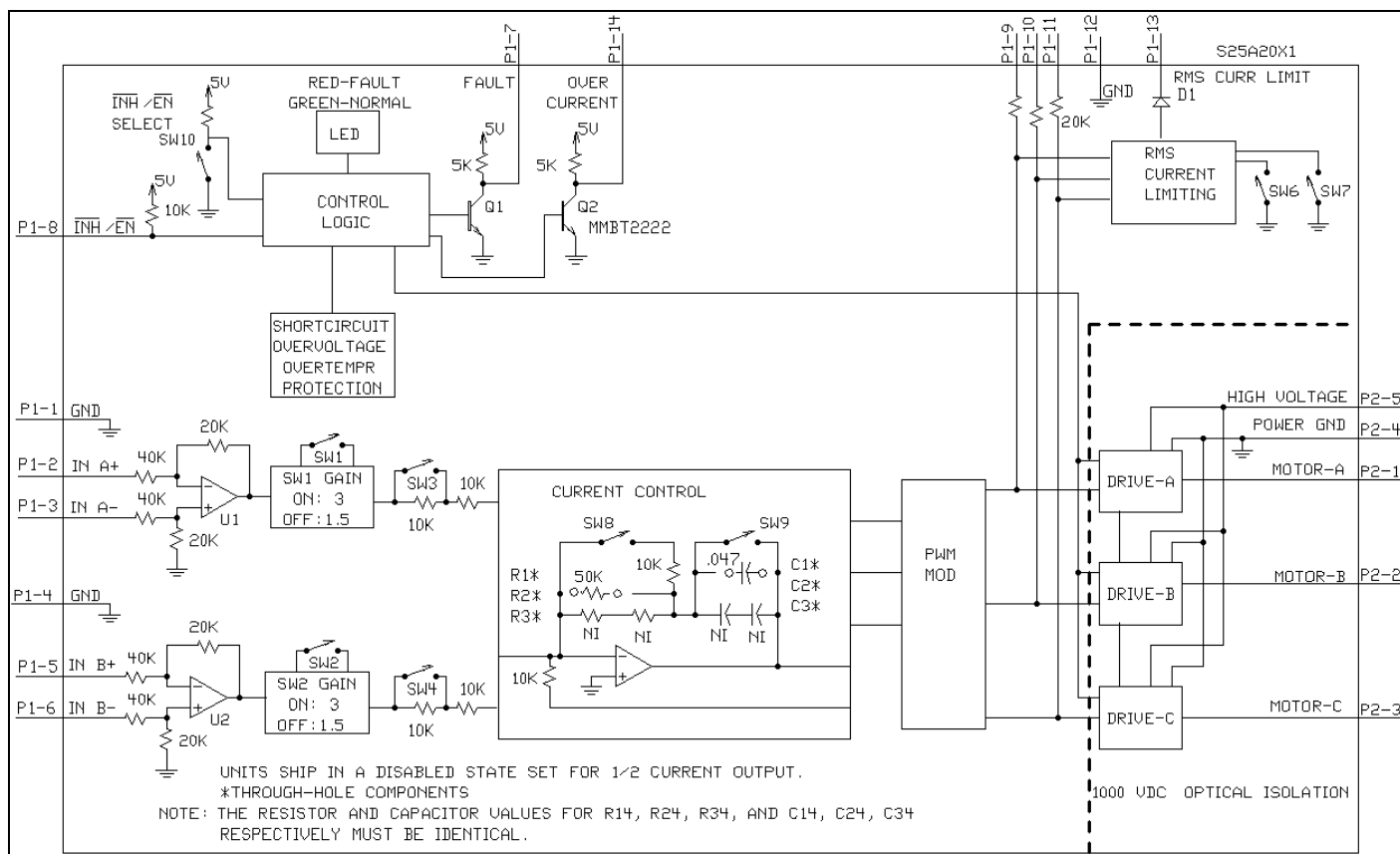

ADVANCED MOTION CONTROLS
 3805 Calle Tecate, Camarillo, CA 93012

Tel: (805) 389-1935, Fax: (805) 389-1165

DESCRIPTION: SX30A Series PWM servo amplifiers are designed to drive three phase brushless motors with sine wave current at a high switching frequency. They require two sinusoidal command signals with a 120-degree phase shift (external commutation). The phase angle must correspond to the position of the motor rotor, while the signal amplitude controls the motor torque. All models typically interface directly with digital controllers. The amplifiers are fully protected against over-voltage, under-voltage, over-current, over-heating, and short-circuits. The SX30A series amplifiers require only a single unregulated DC power supply (all logic and control voltages are generated internally). A red/green LED and two digital outputs indicate operating status.

SPECIFICATIONS:

| POWER STAGE SPECIFICATIONS | MODEL | |
|---|----------------------------------|------------------------|
| | SX30A8* | SX25A20* |
| DC SUPPLY VOLTAGE | 20 – 80 V | 60 – 190 V |
| PEAK CURRENT (2 sec. max., internally limited) | ± 30 A (21.2 Arms) | ± 25 A (17.7 Arms) |
| MAXIMUM CONTINUOUS CURRENT (internally limited) | ± 15 A (10.6 Arms) | ± 12.5 A (8.8 Arms) |
| MINIMUM LOAD INDUCTANCE ** | 200 µH | 250 µH |
| SWITCHING FREQUENCY | 22 kHz nominal | |
| HEATSINK (BASE) TEMPERATURE RANGE | 0° to +65° C, disables if >65° C | |
| POWER DISSIPATION AT CONTINUOUS CURRENT | 60 W | 120 W |
| OVER-VOLTAGE SHUT-DOWN (self-reset) | 86 V | 196 V |
| BANDWIDTH (load dependent) | 2.5 kHz | |

| MECHANICAL SPECIFICATIONS | |
|---------------------------|--|
| POWER CONNECTOR: P2 | Screw Terminals |
| SIGNAL CONNECTOR: P1 | 15 pin D-Sub |
| SIZE SX30A SERIES | 7.35 x 4.40 x 1.45 inches 186.7 x 111.8 x 36.8 mm |
| WEIGHT | 1.5 lb. 0.68 Kg |

*Contact factory regarding CE

**Low inductance motors require external inductors.

PIN FUNCTIONS

| CONNECTOR | PIN | NAME | DESCRIPTION / NOTES | I/O |
|-----------|-----|-------------------|--|-----|
| P1 | 1 | SIGNAL GND | Signal ground | GND |
| | 2 | +REF-IN-A | Differential reference input, maximum ± 15 V, 40K input resistance | I |
| | 3 | -REF-IN-A | | |
| | 4 | SIGNAL GND | Signal ground | GND |
| | 5 | +REF-IN-B | Differential reference input, maximum ± 15 V, 40K input resistance | I |
| | 6 | -REF-IN-B | | |
| | 7 | FAULT OUT | This transistor output becomes high during short circuit, over-voltage, under voltage, and power-on reset. A red LED also indicates a fault condition. | O |
| | 8 | INHIBIT / ENABLE | This TTL level input signal turns off all power devices of the "H" bridge when pulled to ground with SW10=ON. If SW10 = OFF pulling this pin to ground will enable the amplifier. This inhibit will cause a fault condition and a red LED. | I |
| | 9 | CURRENT MONITOR A | Phase current monitor; 7.25 V = maximum peak current setting. | O |
| | 10 | CURRENT MONITOR B | | |
| | 11 | CURRENT MONITOR C | | |
| | 12 | SIGNAL GROUND | Signal ground | GND |
| | 13 | RMS CURRENT LIMIT | The RMS current limit can be controlled by an external voltage; 5 V = maximum RMS current limit. This is referenced to P1-1. No input to this pin is necessary to obtain maximum current. | I |
| | 14 | OVER-CURRENT | This transistor output becomes high if RMS current (in any phase) exceeds RMS current limit. | O |
| | 15 | NC | Reserved | |
| P2 | 1 | MOTOR A | Motor phase A connection | O |
| | 2 | MOTOR B | Motor phase B connection | O |
| | 3 | MOTOR C | Motor phase C connection | O |
| | 4 | POWER GND | Power ground | GND |
| | 5 | HIGH VOLTAGE | DC power input | I |

SWITCH FUNCTIONS

| SWITCH | FUNCTION DESCRIPTION | SETTING | |
|--------|----------------------------|---|---|
| | | ON | OFF |
| 1 | Input Range Selection* | Input range ± 5 V ± 5 V = Max. current when SW1, 2 = ON | Input range ± 10 V ± 10 V = Max. current when SW1, 2 = OFF |
| 2 | | | |
| 3 | Peak Current Limit** | The peak current limit equals 100% of the maximum peak current when SW3 and SW4 are ON. | The peak current limit equals 50% of the maximum peak current when SW3 and SW4 are OFF. |
| 4 | | | |
| 5 | Reserved | | |
| 6 | RMS Current Limit | See Table 1 below. | |
| 7 | | | |
| 8 | Current Loop Gain*** | Decrease | Increase |
| 9 | Current Loop Integrator*** | Recommended setting is OFF. | |
| 10 | INHIBIT/ENABLE SELECT | P1-8 : INHIBIT With SW10=ON, pull P1-8 to ground to inhibit the amplifier. | P1-8 : ENABLE With SW10=OFF, pull P1-8 to ground to enable the amplifier. |

* Switches 1 and 2 must be set the same.

** Switches 3 and 4 must be set the same.

*** See item "6.3 Current Loop Adjustments" in section G for more information.

Units are shipped set for 1/2 current output via SW3 and SW4=off and in the disabled state via SW10=off.

TABLE 1

| SW6 | SW7 | PERCENTAGE OF MAXIMUM CONTINUOUS CURRENT |
|-----|-----|--|
| ON | ON | 100% |
| OFF | ON | 100% |
| ON | OFF | 50% |
| OFF | OFF | 25% |

CURRENT LIMIT

Current limiting for each motor winding is independent. The peak current is maintained for two seconds. If the RMS value of the winding current exceeds the RMS current limit the amplifier shuts off. The shut off condition is indicated by high OVER CURRENT, high FAULT signal, and blinking red LED. The amplifier will re-enable when the RMS current returns to values within the RMS current limit range.

INPUT SIGNAL ISOLATION: All pins on P1 are optically isolated (1000 V) from P2.

ORDERING INFORMATION

Models: SX30A8X, SX25A20

X indicates the current revision letter.

TYPICAL SYSTEM WIRING: See section "G".

MOUNTING DIMENSIONS: See page F-35.

